

Spectrel PTZI-1000

Integrated PTZI long range camera and laser illumination
Datasheet



Features

- Camera zoom range 30 to 1000 mm (33x)
- Digital video output (Streaming IP)
- Laser illuminator bore-sighted to camera
- Fast Pan/Tilt/Zoom operation
- 808 nm semiconductor laser
- True day/night operation
- Wide temperature range, -40°C to +70°C
- Active back focus temperature compensation

Description

The Spectrel PTZI-1000 is an integrated, ruggedized, MIL-grade, ready-to-use, high-precision pan/tilt/zoom camera unit with built-in laser illuminator. The laser illuminator uses the same type of optics as the zoom camera, thus illuminating the camera field of view optimally at all zoom settings.

The camera and laser unit are bore-sighted, ensuring optimal scene illumination regardless of distance to the object, making it ideal for day/night surveillance for border protection, camp perimeter protection, homeland security, and critical infra-structure protection (CIP) applications.

Optical system

The optical system has been developed specifically for use in long range surveillance. It features continuous zoom, with powerful zoom ratio of 30 to 1000 mm, auto-iris and focus adjustment from 3 m to infinity.

The "Auto-Focus on Demand" focuses the camera system automatically by the push of a button.

The lens design incorporates oil-free, low-friction surfaces with special coatings, high-speed motors with zero back-lash and high-precision feedback potentiometers.

Fog penetration

The fog penetration function is designed to automatically increase visibility under conditions such as fog, haze and fire smoke. The camera continuously analyses the picture and once it detects a low-contrast condition, it will automatically enhance the contrast.

Digital Noise Reduction (DNR)

The Digital Noise Reduction in the camera system is a function that analyses the video image and reduces the

noise, particularly in low-light conditions. The analysis is based on a 2- and 3-dimensional algorithm.

Graphic Overlays

The system has a built-in graphic overlay generator that allows arbitrary graphic overlays to be inserted into the image output. Typical overlays are text strings, showing azimuth, elevation, GPS data or hair crosses or other reticles. Graphic overlays can be customized to suit specific user requirements.

Below are typical examples of graphic overlays.

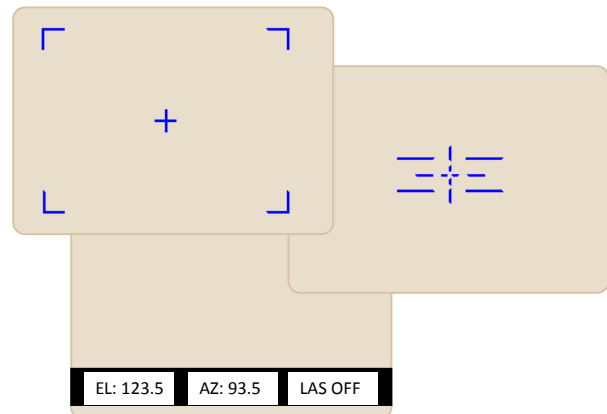

Easy installation and operation

The camera and laser unit has been developed for easy installation and operation in complex surveillance applications. Video output is via IP and the unit is controlled via RS-485 with Pelco-D protocol.

The unit can also be controlled locally with keyboard and also has an analogue video output.

Copenhagen Sensor Technology A/S

Symfonivej 15
DK-2730 Herlev
Denmark

Phone +45 44 92 18 55
Fax +45 44 92 18 56
Web www.copst.com

Document no. M09-000-M00
Revision/Date C/June 2014
Author XB

Spectrel PTZI-1000

Integrated PTZI long range camera and laser illumination
Datasheet



Mechanical outline and dimensions

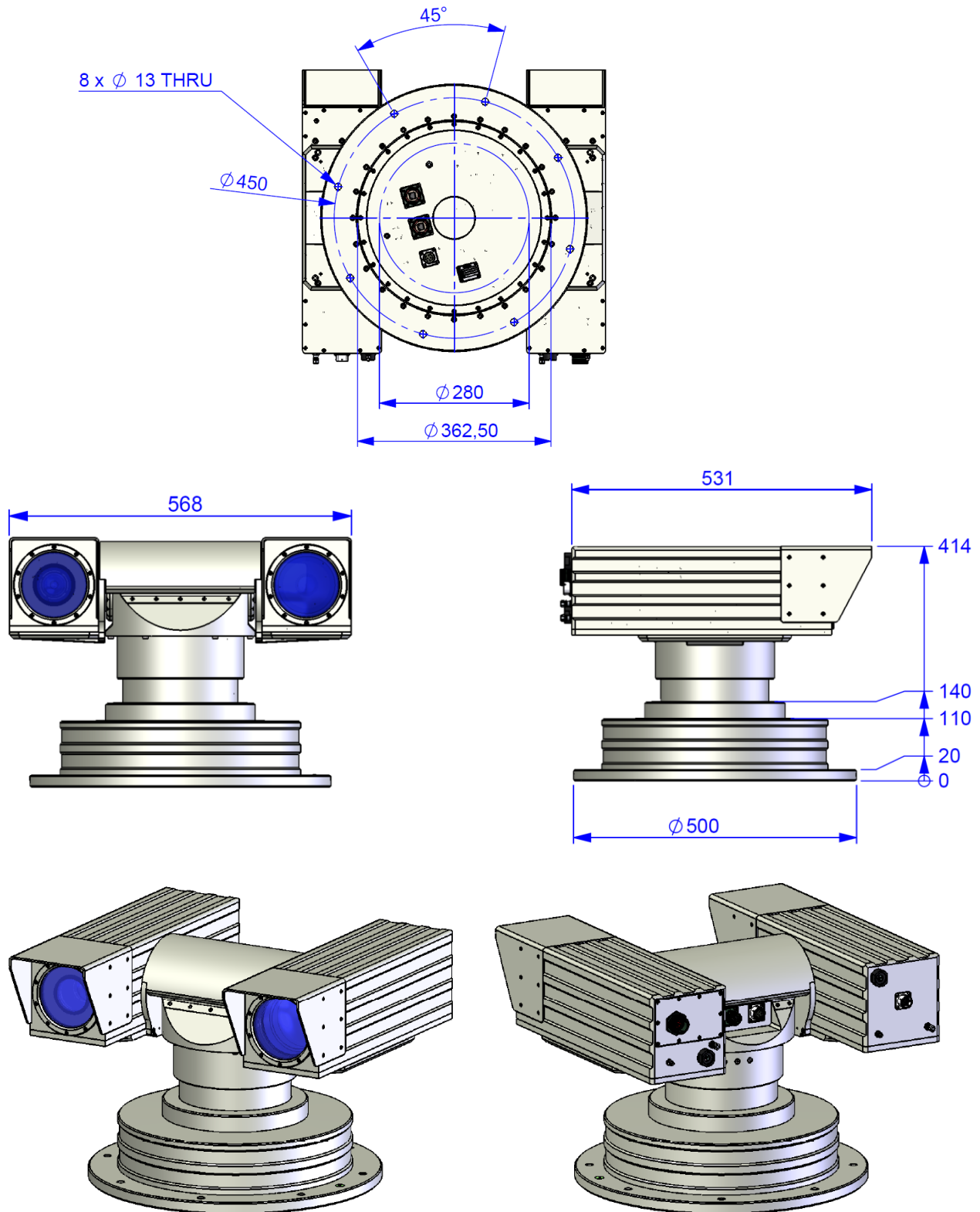

Copenhagen Sensor Technology A/S

Symfonivej 15
DK-2730 Herlev
Denmark

Phone +45 44 92 18 55
Fax +45 44 92 18 56
Web www.copst.com

Document no. M09-000-M00
Revision/Date C/June 2014
Author XB

Spectrel PTZI-1000

Integrated PTZI long range camera and laser illumination

Datasheet



Specifications

Zoom camera Spectrel 121000/336	
Sensor	High-sensitivity colour 1/3" CCD sensor with complementary mosaic
Effective pixels (H x V)	976 x 582
Aspect ratio	4:3
Video output	Video CVBS
Focal length / Hor. field of view	30 to 1000 mm zoom (33x) / 9.3° to 0.28°
System video resolution	540 TVL (15% video modulation, with lens)
Sensitivity	0.030 Lux, 25% video, F4.5
Spectral response	Visible + Near IR (Movable IR-cut filter)
Signal to Noise ratio	> 52 dB, AGC off
Gamma correction	0.45/1.0
Focus range	3 m to ∞ (Active back focus temperature compensation)
Image stabilization	Optional
Laser illuminator Spectrel 8000	
Laser type / optical power	Laser diode / 8 W
Wavelength	808 nm
Range	>6km
Divergence	9.3° to 0.37° (synchronous to the camera zoom)
NOHD	29m for wide beam, 239m for narrow beam
MTTF	10,000 hours @ 100% ≈ 3 years @ normal operation
Pan/Tilt	
Speed, Pan (Azimuth)	Max. 60°/sec, Min. 0.03°/sec continuous speed at 25°
Speed, Tilt (Elevation)	Max. 60°/sec, Min. 0.03°/sec continuous speed at 25°
Position resolution	0.01°
Range of motion, Pan	365°
Range of motion, Tilt	+40°/-45°
Gear head backlash	None
Electrical specifications and functions	
Video output	Streaming IP (H.264 or MJPEG) / Composite CVBS, 1 Vpp, 75 ohm
Commands/status	IP Pelco-D Protocol
Mechanical	
Overall dimensions (H/W/L)	414/568/531mm
Mounting holes	8x Ø13mm
Net weight	52kg
Environmental	
Operating voltage	24 VDC ±10% MIL-1275
Max Current consumption (day/night)	1.5A + 2A for heater/6.5A + 2A for heater
Max Current cons., moving (day/night)	5.5A + 2A for heater/10.5A + 2A for heater
Connectors (power, control)	In accordance with MIL 38999
Chock/vibrations	Vibration 3.05 Grms and chock 11ms 30g
Operating temperature	-40°C to +70°C
Storage temperature	-46°C to +75°C
Surface treatment	Chromit AL TCP / Painting
Protection	IP 65
Bore-sighting retention	±0.2 mRad ≈ ± 2m @ 10km
Bore sight relation Camera/Laser	±0.5 mRad

Copenhagen Sensor Technology A/S

Symfonivej 15
DK-2730 Herlev
Denmark

Phone +45 44 92 18 55
Fax +45 44 92 18 56
Web www.copst.com

Document no. M09-000-M00
Revision/Date C/June 2014
Author XB

Spectrel PTZI-1000

*Integrated PTZI long range camera and laser illumination
Datasheet*



About Us

CST - Copenhagen Sensor Technology A/S is a privately held Danish company specialising in the design and manufacture of high-performance electro-optical solutions for demanding battlefield and surveillance applications.

Founded in 2001, CST has rapidly grown to a mature organisation, capable of serving a global customer base. In modern facilities on the outskirts of Copenhagen, Denmark, CST houses R&D, production, QA and sales and marketing functions. With a collective experience in CCD camera, optics, electronics and software development, the highly skilled staff at CST is committed to creating rugged, durable and innovative electro-optical solutions.

CST is certified to ISO 9001:2008, which applies to the whole process flow of design, development, manufacturing and testing. Furthermore, design and development activities operate in accordance with the ISO 10007:2003 configuration management standard. CST products are not restricted by ITAR.

Customer and OEM solutions

CST has a long tradition of working closely with its customers, identifying unmet needs and creating solutions with sustainable value for the users.

With a strong R&D base at the headquarters in Denmark, CST is able to provide mechanical, optical, software and hardware customisations while meeting the toughest requirements for military, homeland security and high-end surveillance applications.

Whether the need calls for a ruggedized high-precision zoom lens or a highly sensitive CCD camera, or a complete system comprising lens, camera and advanced video processing, CST can offer a fast-track design process. Contact us to discuss your specific requirements. Together we can create a solution that provides the best price and performance ratio.

Copenhagen Sensor Technology A/S

Symfonivej 15 Phone +45 44 92 18 55
DK-2730 Herlev Fax +45 44 92 18 56
Denmark Web www.copst.com

Document no. M09-000-M00
Revision/Date C/June 2014
Author XB